

Technical data sheet for

## **ELECTRIC SALAMANDER**

E91, E91B

- Powerful 6kW infra-red elements
- Left and right heat control
- Branding plate option
- Wall mounting bracket
- Easy clean
- Easy service



E91B

### **Overall Construction**

- Monocoque construction
- Vitreous enamelled front brow
- External panels of 0.9mm stainless steel
- Stainless steel tray under grilling area with grease trough
- Two 3kW infra-red elements

### **Racking**

- Four position racking (flat or inclined)
- Adjustable chrome wire rack with heat resistant handles

### **Controls**

- Large easy use controls
- Heat resistant reinforced control knobs
- Indicator light for each element
- Each side controlled by a 3 heat switch

### **Cleaning and Servicing**

- Access to all parts from front of unit
- Stainless steel and vitreous porcelain enamel surfaces used throughout

# Technical data sheet for ELECTRIC SALAMANDER

## Specifications

**Elements**  
2 x 3kW

**Electrical requirements**  
230-240V, 1P+N+E, 50/60Hz, 6kW, 25A

**Dimensions**  
Width 900mm  
Depth 424mm (455mm with wall mounting bracket)  
Height 456mm

**Cooking area**  
Rack size 610mm x 310mm, 1890cm<sup>2</sup>  
Branding Plate 610mm x 310mm, 1890cm<sup>2</sup>

**Nett weight**  
36kg

**Packing data**  
0.31m<sup>3</sup>, 63kg  
Width 945mm  
Depth 520mm  
Height 635mm

**Electrical connection**  
230-240V 1 phase hard wired via terminal block at back of unit 64mm from right side and 90mm from bottom of unit

**Options**  
100mm high feet for bench mounting  
Branding plate

E91

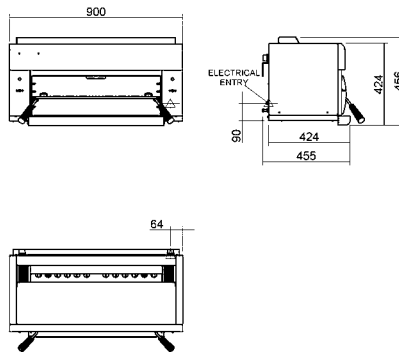

**MOFFAT®**

Australia  
[www.moffat.com.au](http://www.moffat.com.au)  
New Zealand  
[www.moffat.co.nz](http://www.moffat.co.nz)  
[www.bluesealevolution.com](http://www.bluesealevolution.com)

Australia  
Moffat Pty Limited

Victoria/Tasmania  
740 Springvale Road  
Mulgrave, Victoria 3170  
Telephone 03-9518 3888  
Facsimile 03-9518 3833  
[vsales@moffat.com.au](mailto:vsales@moffat.com.au)

New South Wales  
Telephone 02-8833 4111  
[nswsales@moffat.com.au](mailto:nswsales@moffat.com.au)

South Australia  
Telephone 03-9518 3888  
[vsales@moffat.com.au](mailto:vsales@moffat.com.au)

Queensland  
Telephone 07-3630 8600  
[qldsales@moffat.com.au](mailto:qldsales@moffat.com.au)

Western Australia  
Telephone 08-9202 6820  
[bgarcia@moffat.com.au](mailto:bgarcia@moffat.com.au)

New Zealand  
Moffat Limited

Christchurch  
16 Osborne Street  
Christchurch 8011  
Telephone 03-389 1007  
Facsimile 03-389 1276  
[sales@moffat.co.nz](mailto:sales@moffat.co.nz)

Auckland  
Telephone 09-574 3150  
[sales@moffat.co.nz](mailto:sales@moffat.co.nz)



Designed and manufactured by

**MOFFAT®**

ISO9001

All Blue Seal products are designed and manufactured by Moffat using the internationally recognised ISO9001 quality management system, covering design, manufacture and final inspection, ensuring consistent high quality at all times.

In line with policy to continually develop and improve its products, Moffat Limited reserves the right to change specifications and design without notice.

Printed in China  
© Copyright Moffat Ltd  
Moffat / 7.09 / 1140

